

SIERRA COLLEGE
CENTER FOR APPLIED TECHNOLOGY

DRAFTER S DICUS	DWG NO. SPRING WIRE JIG	REV A
SCALE: FULL	JULY 20, 2012	SHEET: 1 of 2

- NOTES:
1. MAT'L $\frac{3}{16}$ " ANGLE IRON
 2. 2 - $\frac{1}{2}$ #10-32 UNF SOCKET HEAD CAP SCREW

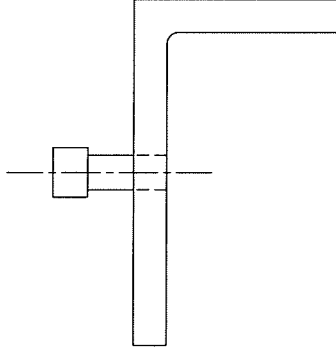
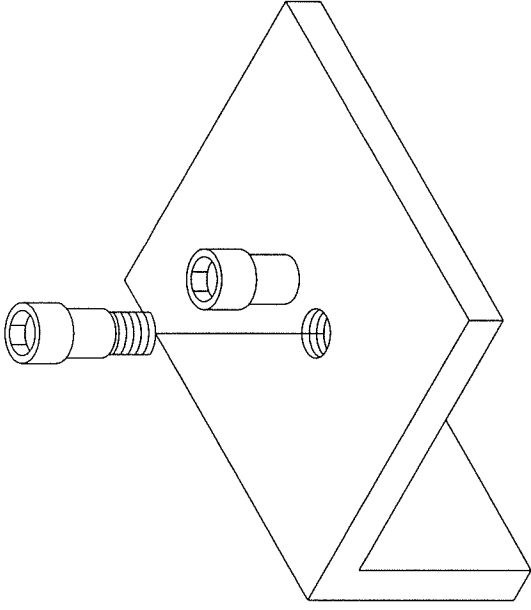
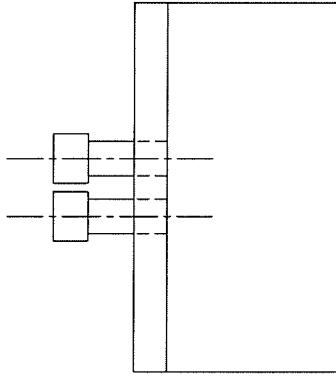
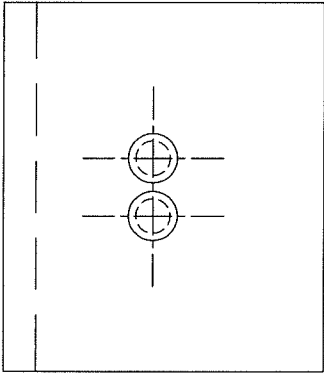

- NOTES:
1. MAT'L $\frac{3}{16}$ " ANGLE IRON
 2. 2 - $\frac{1}{2}$ #10-32 UNF SOCKET HEAD CAP SCREW

SIERRA COLLEGE
 CENTER FOR APPLIED TECHNOLOGY

DRAFTER	DWG NO.	REV
S DICUS	SPRING WIRE JIG	A

SCALE: FULL JULY 20, 2012 SHEET: 2 of 2